

PLANNING REPORT

TO: PLANNING ADVISORY COMMITTEE

FROM: PLANNING AND DEVELOPMENT

MEETING DATE: TUESDAY, MARCH 28, 2023

SUBJECT: DP2023-03 – 399 KING STREET EAST
CLASS III DEVELOPMENT PERMIT

Background:

Property: 399 KING STREET EAST

Legal Description: PLAN 223 LOT 1137 LOT 1138 RP 28R7427 PART 2
TOWN OF GANANOQUE

Official Plan: GENERAL COMMERCIAL

Development Permit: PROGRESSIVE COMMERCIAL DISTRICT

Lot Coverage: 60%

Purpose and Effect:

To amend the existing site plan application to permit a new restaurant in the existing commercial building and to reinstate the drive-through operation in approximately the same location used previously by a restaurant. The existing 283m² (3045ft²) building will be retrofitted to accommodate the new Popeyes restaurant with drive-through.

Background:

A pre-consultation meeting was held with the applicant and Planning staff on December 2022 to discuss the conversion of the existing vacant building to Popeyes restaurant with drive-through similar to the restaurant as approved in 1994. At that time the restaurant was subject to Site Plan Control with the Town registered on title as Inst. 252820 on July 19, 1994. The restaurant ceased operations approximately 25-30 years ago and has not been operating as a restaurant since that time.

The most recent use of the building was for the purpose of a retail store called Partsource which has also ceased in operations. A site plan was applied and registered on title as LE52438 December 19, 2012 for the placement of temporary storage containers. Pending approval of this application, the Site Plan on title in this regard (storage containers) may be removed.

In order to proceed with the development of the proposed restaurant, the applicant is required to undertake an amendment to the 1994 Site Plan Agreement and drawings to include the revised drawing submission which illustrate the drive-through requirements as per the Development Permit By-law. The drive-through is proposed to be located along the western interior lot line and will remain along the south side of the building as per the previously approved Site Plan. The drive-through will continue to be accessed from King Street East and exit onto James Street.

As per the SP01 Site Development Plan for Popeyes, the digital order screen and main menu will be located to the rear of the waste collection structure and the drive-through window will be located in approximately the same location as the previous Burger King restaurant.

The building area and site layout is not proposed to change. The former restaurant provided a building area of 283/m² requiring 26 parking spaces and 29 parking spaces were provided. The 29 spaces continues parking spaces continues to meet the Development Permit By-law including 2 Barrier Free parking spaces.

Site Plan:

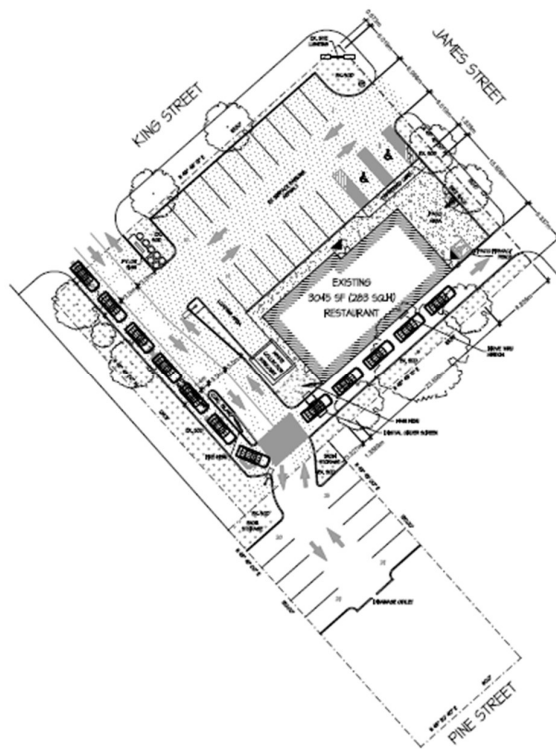



View from the southeast corner of the property looking at the existing building.

PROVINCIAL POLICY STATEMENT:

The Provincial Policy Statement, 2020 (PPS) provides direction on matters of provincial interest pertaining to land use matters and all development proposals must be consistent with the policies therein. The full PPS document can be found at <https://www.ontario.ca/page/provincial-policy-statement-2020>. Policies which repeat or are not relevant to the current proposal have been omitted from commentary below.

1.0 Building Strong Healthy Communities

1.1.1 Healthy, livable and safe communities are sustained by:

- a) promoting efficient development and land use patterns which sustain the financial well-being of the Province and municipalities over the long term;
- c) avoiding development and land use patterns which may cause environmental or public health and safety concerns;

1.1.3.1 Settlement areas shall be the focus of growth and development.

1.1.3.2 Land use patterns within settlement areas shall be based on densities and a mix of land uses which:

- a) efficient use land and resources;
- b) are appropriate for, and efficiently use, the infrastructure and public service facilities which are planned or available, and avoid the need for their unjustified and/or economical expansion;

1.3 Employment

1.3.1 Planning authorities shall promote economic development and competitiveness by:

- a) providing for an appropriate mix and range of employment, institutional, and broader mixed uses to meet long-term needs;

- b) providing opportunities for a diversified economic base, including maintaining a range and choice of suitable sites for employment uses which support a wide range of economic activities and ancillary uses, and take into account the needs of existing and future businesses;
- c) facilitating the conditions for economic investment by identifying strategic sites for investment, monitoring the availability and suitability of employment sites, including market-ready sites, and seeking to address potential barriers to investment;
- d) encouraging compact, mixed-use development that incorporates compatible employment uses to support liveable and resilient communities, with consideration of housing policy 1.4.

1.6.6 Sewage, Water and Stormwater

1.6.6.2 Municipal sewage services and municipal water services are the preferred form of servicing for settlement areas to support protection of the environment and minimize potential risks to human health and safety. Within settlement areas with existing municipal sewage services and municipal water services, intensification and redevelopment shall be promoted wherever feasible to optimize the use of the services.

1.7 Long-Term Economic Prosperity

1.7.1 Long-term economic prosperity should be supported by:

- a) promoting opportunities for economic development and community investment-readiness;
- c) optimizing the long-term availability and use of land, resources, infrastructure and public service facilities;
- d) maintaining and, where possible, enhancing the vitality and viability of downtown and mainstreets;

COMMENT:

The proposed use is consistent with policies pertaining to development in the general commercial designation. The building was originally approved for the purpose of a restaurant with drive-through. The proposed Popeye’s restaurant with drive-through is consistent with the previous use, access and parking with additional parking spaces to be located closer to Pine Street.

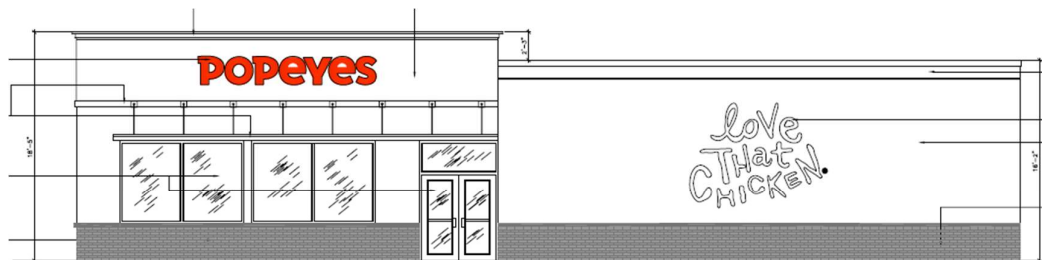

① PARKING SIDE EXTERIOR ELEVATION
SCALE 1/4" = 1'-0"

North Elevation – Popeyes

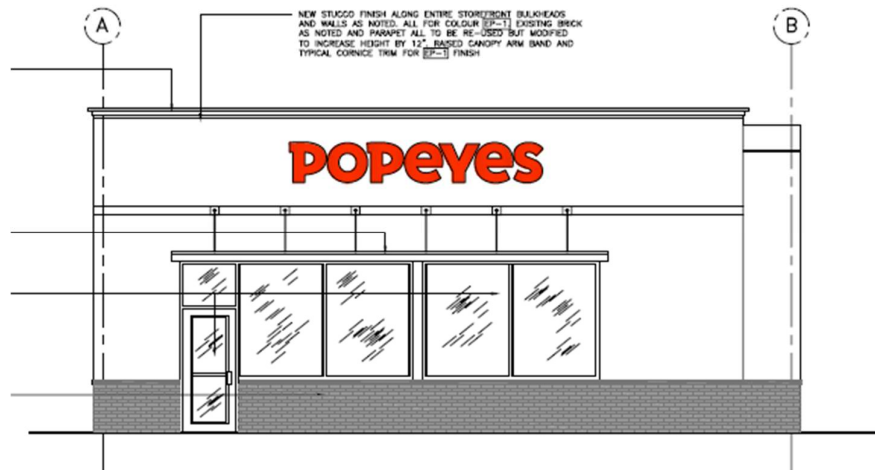

East Elevation - Popeyes

OFFICIAL PLAN:

Goals and Objectives (3.3.1) Commercial

The goal of the Commercial Designation is to provide a supportive land use policy framework which reduces constraints for commercial development while ensuring that existing and future commercial uses will contribute to the Town of Gananoque's small town character.

The objectives of this designation are to:

1. Support a diverse range of commercial uses that meet the existing and future needs of the community and reduces the need for residents to shop elsewhere;
2. Accommodate a range of commercial formats from smaller pedestrian-orientated stores in the central King Street area to highway commercial type uses near Highway 401;
3. Enhance the form and character of each commercial area in the Town and work to create a distinct community identity for each; and
4. To encourage the maintenance and improvement of existing commercial buildings.

Permitted Uses:

Development within the Commercial Designation is identified on Schedule C of the Official Plan. The distinct nature of the commercial area will be established through the Zoning By-law and now the Development Permit By-law. All new commercial uses will be subject to the Development Permit By-law.

The following uses shall generally be permitted in the Commercial Designation which include retail and service commercial development intended to serve the needs of local residents which include:

1. Retail stores
2. Personal service establishments
3. Professional offices
4. Restaurants
5. Banks and financial services

6. Travel accommodations, and
7. Community services

General Commercial Policies (3.3.2.1.2)

All new commercial development and infill commercial development in existing areas shall provide adequate off-street parking. Access to parking shall be designed to minimize conflict between pedestrian and vehicular traffic. Access to commercial development from residential streets shall be avoided.

New or redeveloped commercial uses in the General Commercial designation shall be orientated to pedestrian and vehicular traffic with an emphasis on the ease of movement for pedestrians between commercial establishments.

Council may consider the development of commercial design guidelines or the use of a Development Permit System to influence or control design of building mass and scale, facades, streetscape design, pedestrian amenities, signage and gateway features. In the absence of additional direction site plan control will be applied to ensure that the general intent of these policies is achieved.

COMMENT:

The proposed use is consistent with the General Commercial policies of the Official Plan designation. The proposed Popeyes restaurant with drive-through will reinstate the original purpose of the former restaurant to provide a commercial service that meet the existing and future needs of the community and reduces the need for residents to shop elsewhere. The new Popeyes restaurant is regulated through the Development Permit application.

Adjacent Uses

The subject property is adjacent to lands designated General Commercial and is adjacent to an existing residential dwelling to the south and Gananoque Secondary School, Gananoque Motors Limited to the east and north and a mixed use building to the west.

DEVELOPMENT PERMIT:

The subject property is designated Progressive Commercial District within the Development Permit By-law. The intent of the Progressive Commercial District designation is to provide for opportunities that link the Traditional Core with the Gateway Commercial designation. The area enjoys both traditional and modern built structures and it is desirable to integrate the character to provide for an interesting streetscape.

The current proposal would permit the proposed restaurant and a drive-through facility is identified as a discretionary use.

Section 7.4 Additional Provisions Discretionary Use

All discretionary uses shall be subject to the Class III Development Permit approval stream. The permit applications shall be supported by a report and related architectural elevation drawings, prepared by qualified professionals, which demonstrate that the cultural and architectural heritage integrity of the Progressive Commercial District designation have been respected and enhanced by the proposed development. The Class III permit shall also require demonstration that the proposed discretionary use can

be appropriately developed on the basis of the land uses functional requirements such as street frontage, access, yard setbacks, vehicular movements and parking requirements, safety etc.

Section 7.5 Design Criteria Progressive Commercial Designation

Where a progressive commercial use is located adjacent to a residential use, a 3.0 metres (9.8 ft) landscaped buffer strip shall be provided between the commercial and the residential use.

When a building is altered or a new building is proposed in the Progressive Commercial designation the assembly of the streetscape as a whole take's precedence over any individual building. Design elements such as siting, massing, proportion, composition, material choice, finish, and detail contribute to "fitting in" and complementing existing inventory.

All development projects need not exclusively mimic existing built form elements but should blend in with existing elements of character, scale and design. New work should be complementary in appearance to the original.

Garbage receptacles are to be enclosed by wood screen or planted hedge. Garbage enclosures are to be fenced and screened with soft landscape elements and are only permitted in the rear yard.

Buildings should be orientated towards the street and parking provided in the rear or side of building. Where property fabric will not lend itself to the provision of parking except at the front of the building, parking will be buffered and screened by landscape materials providing an element of all season screening.

Buffers shall consist of plant material screens and structural elements that are designed and maintained in a staggered or undulating manner to create a more natural looking landscape. Not less than 50% of the landscaped area shall consist of natural plantings of grass, lawns, trees, shrubs and flowers. Soft landscape materials may also include shrubs and planting at foundation base, container planting consisting of urns, planters, window boxes or suspended baskets.

Street trees are to be provided wherever possible. Planters and containers shall be considered as an alternative where insufficient area exists for the long term health of the tree.

Elements of Progressive Commercial Design Criteria:

- Directional emphasis is to be maintained along the streetscape.
- If alterations are required to provide barrier free access, ramps and railings should be designed to blend in with the original building as much as possible. This will include the use of wood and ornamental metal.
- Site Furnishings such as light fixtures, park benches, waste receptacles and street signage shall be in accordance with municipal standards.
- Crosswalks will be defined with prefabricated concrete pavers or poured in place concrete.

COMMENT:

As the property was initially developed for the purpose of a restaurant, the existing building, which faces King Street East, will be renovated to accommodate for a Popeye's restaurant. The site contains existing landscaping containing shrubs, trees and grass with existing asphalt, concrete surfaces and entrance/exits from King Street East and James Street. The existing waste collection structure will be used for the purpose of collecting waste.

Section 7.2 Site Provisions

Section 7.2 of the By-law establishes site requirements for the permitted and discretionary uses. The provisions for the proposed site plan and the provisions for the accessory greenhouse are as follows:

Provision	Required	Existing/Proposed
Lot Area (min.)	464 m ²	2,771.9 m ²
Lot Coverage (max.)	60%	10.2%
Lot Frontage (min.)	15 m	39.6 m
Front Yard Setback (min.)	7 m	23 m+
Exterior Side Yard Setback (min.)	4.5	8.826 m
Interior Side Yard Setback (min.)	1.2 m	22 m
Rear Yard Depth (min.)	6 m	6.337 m
Building Height (max.)	12 m	5.6 m

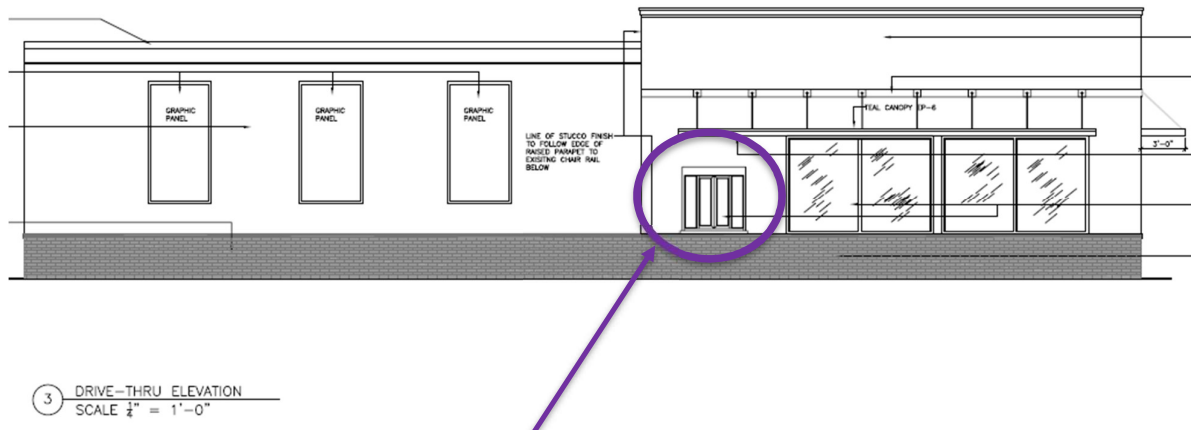

South Elevation with Drive-through Take-Out Window - Popeyes

Drive-through Operations (3.10)

A drive-through facility may be provided in conjunction with any restaurant, bank or bank machine, a gasoline pump at a gas bar or service station, a pharmacy or drug store or with any use that is associated with a shopping centre. A traffic impact study may be required before approval to support the proposed development. A drive-through facility is required to provide off-street motor vehicle queuing space as outlined in Section 3.32.

All queuing spaces must be 2.75 metres (9.0 feet) in width by 6 metres (19.7 feet) in length. All queuing spaces must be separated by at least 3 metres (9.8 feet) from any residential use. Any yard abutting a residential use must be screened by solid fencing at

least 1.5 metres (4.9 feet) in height. All drive-through facilities must provide screening from any public right of way to minimize any visual impacts of the use.

Pedestrian walkways should not intersect the drive-through aisles, but where they do, they shall have clear visibility, and they must be emphasized by enriched paving or striping.

COMMENT

The queuing lane is proposed to be 3.0 metres wide and can accommodate for vehicles 6 metres in length. The drive-through lane, along the western interior lot line, is partially screened with existing trees. There is an existing light standard at the northeast corner of the property.

The applicant has indicated that the drive-through will be operation from 11am to 9pm and that approximately 25% of the customers will be using the drive-through lane. The speaker unit has a sensitive microphone and a focused speaker that emits low residual sound. Additionally, Staff have recommended that the site plan reference a dense tree line or evergreen along the property line adjacent the residential dwelling to create a privacy and sound buffer than a solid fence to create additional greening of the site.

Public Works reviewed the traffic flows and congestion and indicated that initial congestion and confusion may occur initially, however, with the markings on asphalt will direct traffic with the pre-existing conditions. Additionally, the traffic coming out of the drive-through is felt to minimal and no further requirements of the proponent in this regard.

Parking and Storage of Vehicles (3.32)

The By-law indicates that for a restaurant and restaurant drive-in that the required number of parking spaces for this use are 1 space per 10 m² (107.6 ft²) of gross floor area and 11 queuing spaces for a restaurant.

The By-law further provides for parking space sizes, ingress and egress and barrier free parking.

COMMENT:

The number of parking spaces provided for the Popeyes Restaurant is 29 including two barrier free parking spaces closer to the front of the building at the James Street entrance/exit. This meets the parking requirement of 1 space per 10 m² of gross floor area for the existing building that is 283 m². A barrier free entrance has been provided at the east side of the building closer to James Street with a patio privacy fence screening the access from the drive-through lane. A depressed curb will provide access to the two barrier free parking spaces at the northwest side of the building.

The queuing lane can accommodate for 12 vehicles and 11 queuing spaces are required as per the Development Permit By-law. The length of the queuing spaces has not been identified on the Site Plan drawing.

The proposed site plan additionally identifies and area for bicycle racks in the area of the outdoor patio.

CIRCULATION TO AGENCIES

Circulation to all property owners within 120m of the site and the prescribed agencies (comments received to date):

CAO	
Chief Building Official	No objection
CRCA	No concerns
School Boards: CDSBEO and UCDSB	
Utilities: Bell Canada/Canada Post/ Cogeco/Enbridge Gas/ Eastern Ontario Power/Hydro One (OPG)	Bell Canada – Comments will be provided if required. Cogeco – No comment Enbridge – No comment unless in proximity Hydro One – No comment
EMS: Fire/LG Paramedic/Police	Fire – No comment
Public Works, Water/Sewer Utilities	Snow storage areas seem to be inadequate for the area of the parking lot. Snow accumulation should not impact the ROW and/or sightlines. All entrances and exits are pre-existing and traffic concerns are minimal.
Leeds Grenville Lanark District Health Unit	No objection. The Health Unit provided “A Guide to Opening a Food Premises” which was provided to the applicant.
Neighbourhood: Posting and 120m Circulation	Letter of support dated March 10, 2023 from Jamie & Dewey Hall of Gan Chev, attached.

Staff have no objection to DP2023-03 Popeyes Restaurant – 399 King Street East, for the conversion of the existing structure to accommodate the new restaurant subject to the following conditions:

- A final set of drawings be submitted prior to the registration of the Development Permit Agreement to include tree buffering, painted pedestrian walkway from King Street East to the restaurant and minor changes for clarification.
- The Owner enter into an amending Development Permit Agreement within one year of the Notice of Decision or the approval may lapse; and
- All costs associated with fulfilling the conditions of this decision are borne by the Owner.

NOTICE OF PUBLIC MEETING Proposed Class III Development Permit

TAKE NOTICE THAT the Planning Advisory Committee/Committee of Adjustment for the Town of Gananoque will hold a Meeting on **TUESDAY, MARCH 28, 2023 at 6:00 P.M.** via **TELECONFERENCE*** to provide a recommendation to Council on the application below.

AND TAKE FURTHER NOTICE that the Council for the Corporation of the Town of Gananoque will hold a Public Meeting on **TUESDAY, APRIL 4, 2023 at 6:00 P.M.** via **TELECONFERENCE*** and **IN-PERSON** in the TOWN OF GANANOQUE COUNCIL CHAMBERS, 30 KING STREET EAST to consider the application.

*The **TOLL-FREE PHONE NUMBER** and **ACCESS CODE** will be found on the meeting agenda, posted to the Town website at <https://www.gananoque.ca/town-hall/meetings> prior to the meeting.

File No. **DP2023-03**

OWNER/APPLICANT:

995423 Ontario Inc.

The property municipally and legally described as
399 KING STREET EAST
PLAN 223 LOT 1137 LOT 1138 PLAN 28R-7427 PART 2
TOWN OF GANANOQUE

has applied to the Town of Gananoque for a Development Permit to
DEVELOP THE EXISTING BUILDING TO A RESTAURANT

Additional information in relation to the proposed development permit is available for inspection on the Town website at <https://www.gananoque.ca/town-hall/meetings>, by emailing assistantplanner@gananoque.ca or by calling Trudy Gravel, Assistant Planner at 613-382-2149 ext. 1129.

If you wish to provide comment or input you may do so at the public meeting or in writing prior to the meeting.

Note: Only the applicant of a development permit has a right to appeal a decision or non-decision on an application to the Ontario Land Tribunal where the application meets the requirements established through the official plan and development permit by-law.

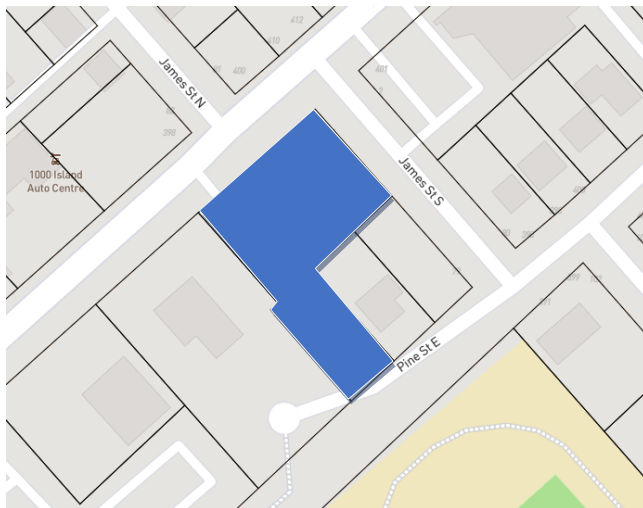

DATED this 6TH day MARCH, 2023

Brenda Guy
Manager of Planning and Development

PROPOSED PLAN

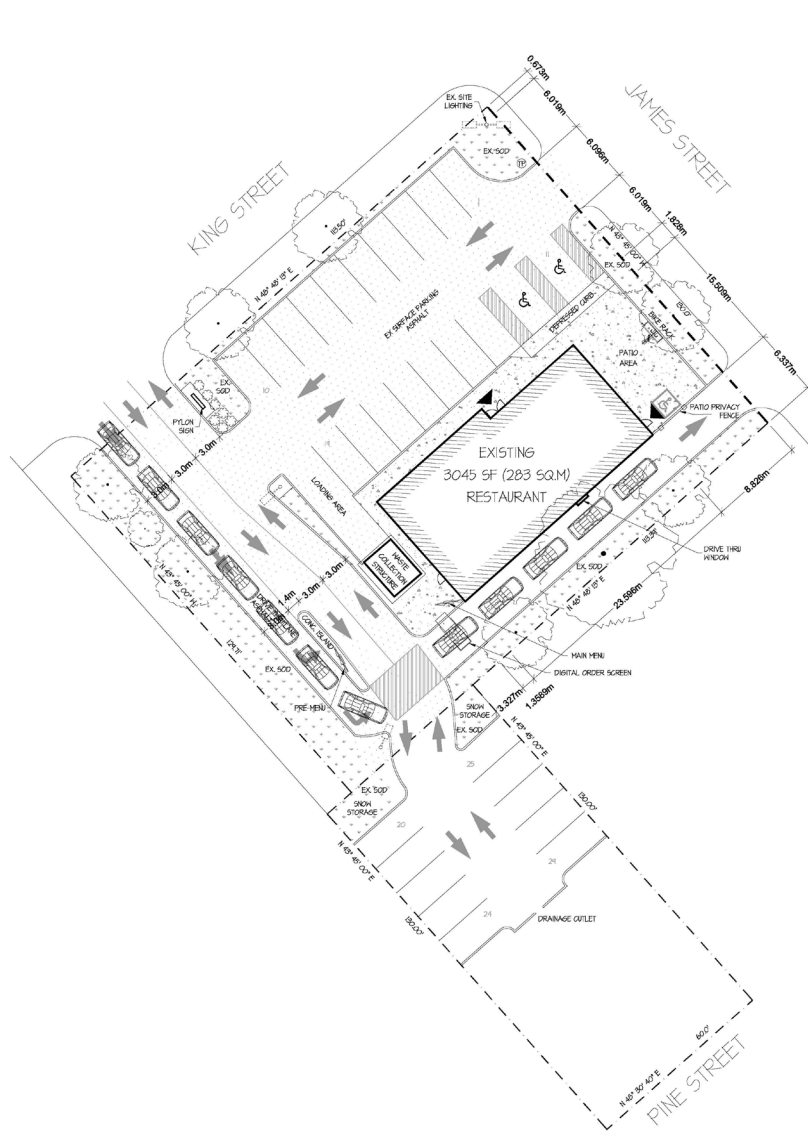

STATISTICS	
LEGAL DESCRIPTION	PART OF LOT 15 PART 3 TOWN OF GANANOQUE CSDTY OF LEES
PARKING PROVIDED	24 STALLS
PARKING REQUIRED	24 STALLS
BUILDING AREA	3045 SQFT (283 SQM)
PROPERTY AREA	24031 SQFT
GREENING	0
ALL SITE SERVICES AS EXISTING ALL SITE STORM DRAINAGE AS EXISTING	

LEGEND	
	PROPERTY LINE
	TRAFFIC DIRECTION
	LIGHT STANDARD
	ENTRANCE/EXIT
	GRASS
	SHRUB BED
	CONCRETE
	ASPHALT PAVING
	SURFACE PARKING
	EX. SHRUB
	EX. TREE
	BARRIER FREE PARKING

DO NOT SCALE DRAWINGS
CHECK AND VERIFY ALL DIMENSIONS
PROCEEDING WITH THE WORK.
THESE DRAWINGS HAVE BEEN DESIGNED
CONFORMANCE WITH THE ONTARIO

REV.	DATE	DES.
1	2023.02.07	ISSUED FOR
2		
3		



CPPS 20 2303

APPLICATION FOR DEVELOPMENT PERMIT APPROVAL
Section 70.2 of the Planning Act, RSO 1990, as amended

This application form **MUST** be accompanied with **all** the submission requirements in order to be considered a complete application. Incomplete applications will not be processed until all information is provided.

A meeting with Community Development staff is **REQUIRED PRIOR TO SUBMISSION** of this application. At that time, approval stream and submission requirements will be determined. **ALL** applications require the following:

- Complete application form signed including declaration of applicant.
- Copy of the deed of property or offer to purchase and sale
- Two (2) large scale copies of all plans being submitted, two reduced 8.5" x 11" of each plan and one electronic copy in pdf format. Plans are to be in a standard scale format (1:250 1:500)
- Application fee payable to the Town of Gananoque:
 - Class I \$500
 - Class II \$1,500
 - Class III \$1,700
 - Amendment to Class I, Class II or Class III \$700
- Deposit fee in the amount of \$2,000 payable to the Town of Gananoque for peer reviews of studies for a Class II/Class III
- Copy of the most recent survey of the subject property
- Cataraqui Region Conservation Authority.** Subject to review and a separate cheque payable to the Cataraqui Region Conservation Authority in the amount of \$305.00. Clearance letter will be required by the Town.

CONTACT INFORMATION

Municipal Freedom of Information and Protection of Privacy Act – Personal Information on this form is collected under authority of The Planning Act and will be used to process this application.

Name of Applicant: 995423 ONTARIO INC.	Complete Address including Postal Code: 777 KING ST. E. GANANOQUE, ON K7G 1H4	Phone: 613-382-7292 Fax: 613-541-1453 E-mail: JEFF@RHCHOTELS.CA
Name of Property Owner (if different than applicant): SAME	Complete Address including Postal Code:	Phone: _____ Fax: _____ E-mail: _____
Architect/Designer/Planner: N/A	Complete Address including Postal Code:	Phone: _____ Fax: _____ E-mail: _____
Engineer: N/A	Complete Address including Postal Code:	Phone: _____ Fax: _____ E-mail: _____
Ontario Land Surveyor: N/A	Complete Address including Postal Code:	Phone: _____ Fax: _____ E-mail: _____

Street or Property Address (if applicable): **399 KING ST. E.**

LEGAL DESCRIPTION

Lot/Con/Plan: **Plan 223 LOT 1137 LOT 1138 RP 28R7427 PART 2**

Frontage: 165' KING	Depth: 130 JAMES	Area (sq.m): 67 AC	Area (acres): _____
-------------------------------	----------------------------	------------------------------	------------------------

SUBMISSION REQUIREMENTS

The applicant is responsible for ensuring that the submission requirements are met, including confirming that all the information listed below is shown on the required plans by checking off each box.

- Site Plan(s)** including scaled accurate measurements of:
 - o Title, location and date of project including legend and scale (graphic bar scale as well as written ratio scale);
 - o Dimensions and areas of the site including existing natural and artificial features i.e: buildings, watercourses, wetlands, woodlands.
 - o Dimensions and gross floor area of all building and structures to be erected;
 - o Existing structures to be retained, removed or relocated;
 - o Distances between lot lines and the various buildings, structures, parking areas, driveways and other features;
 - o Proposed elevation of finished grades including area to be filled or excavated, retaining walls, drainage ditches;
 - o Parking areas including number, size of spaces and dimensions. The plans shall have regard for **Ontario Regulation 413/12 made under Accessibility for Ontarians with Disabilities Act, 2005**. This shall include, but not be limited to, providing appropriate designated parking spaces and unobstructed building access features.
 - o Access driveways including curbing and sidewalks
 - o Proposed fire routes and fire route sign locations
 - o Dimensions and locations of loading zones, waste receptacles and other storage spaces;
 - o Location, height and type of lighting fixtures including information on intensity and the direction in which they will shine relative to neighbouring streets and properties;
 - o Location of sign (sign permit to be applied for through the Building Permit process) as per By-law 2005-41;
 - o Location, type and size of any other significant features such as fencing, gates and walkways.

- Drainage Plan(s)** including scaled accurate measurements of:
 - o Drainage Plan must demonstrate proposed development is handled on-site and does not infringe on neighbouring properties;

- Landscape Plan(s)** including scaled accurate measurements of:
 - o Landscape Plan showing size, type and location of vegetation, areas to be seeded or sod. Plan to show existing landscape features to be retained, removed or relocated;

- Site Servicing Plan(s)** including scaled accurate measurements of:
 - o Site Servicing Plan (plan/profile) including layout of existing water, sewer, gas lines, proposed connections, utility easements, fire hydrants, hydro poles, lighting, trees, transformers and pedestals.

- Grade Control and Drainage Plan(s)** including scale accurate measurements of:
 - o Existing elevations on subject and adjacent lands and long centerline or adjacent street lines, which are to be geodetic;
 - o Location of any creeks, ravines or watercourses with elevations and contours;
 - o Arrows indicating the proposed direction of flow of all surface water;
 - o Location and direction of swales, surface water outlets, rip-rap, catch basins, rock, retaining walls, culverts
 - o Existing and/or proposed right-of-ways or easements

- Elevation and Cross-Section Plan(s)** including scale accurate measurements of:
 - o Drawings that show plan, elevations and cross section views for each building or structure to be erected;
 - o Conceptual design of building;
 - o Relationship to existing buildings, streets and exterior areas to which members of the public have access to;
 - o Exterior design including character, scale, appearance and design features of the proposed building;
 - o Design elements of adjacent Town road including trees, shrubs, plantings, street furniture, curbing and facilities designed to have regard for accessibility
 - o Photographs of the subject land and abutting streetscape on both side of the street

- Supporting Studies and Reports.** Technical reports/plans or studies may be required to assist in the review process of a Development Permit Application. Applications for Development Permit may be required to submit the following studies or reports. Applicants should consult with Municipal staff to determine site specific requirements:

<input type="checkbox"/> Servicing options report	<input type="checkbox"/> Phase I Environmental Study and if investigation as required
<input type="checkbox"/> Hydrogeological Study	<input type="checkbox"/> Noise and/or vibration study
<input type="checkbox"/> Drainage and/or stormwater management report	<input type="checkbox"/> Source Water protection study
<input type="checkbox"/> Environmental Impact Assessment for a natural heritage feature or area	<input type="checkbox"/> MDS I or II calculation
<input type="checkbox"/> Archaeological Assessment	<input type="checkbox"/> Minimum Separation distance calculation for an industrial use or a waste management facility
<input type="checkbox"/> Influence area study for development in proximity to a waste management facility or industrial use	<input type="checkbox"/> Confirmation of sufficient reserve sewage system capacity and reserve water system capacity
<input type="checkbox"/> Traffic Study	<input type="checkbox"/> Vegetation Inventory and/or Tree Preservation Plan
<input type="checkbox"/> Heritage Resource Assessment	<input type="checkbox"/> Supporting Land Use Planning Report
<input type="checkbox"/> Mine hazard rehabilitation assessment	

Existing Use(s):			
Length of time the existing use of the subject lands have continued:		28 YEARS 1994	
Has the property been designated as a Heritage Site?		<input type="checkbox"/> Yes	<input checked="" type="checkbox"/> No
Is the property presently under a Site Plan Agreement?		<input checked="" type="checkbox"/> Yes	<input type="checkbox"/> No
Has the property ever been subject of an application under Section 34 (Zoning), 41 (Site plan) or 46 (Minor Variance) of the Planning Act?		<input checked="" type="checkbox"/> Yes	<input type="checkbox"/> No
If yes, provide the file number and the status of the application?		SITE PLAN 1994 + 2012	
Proposed Use(s):			
Restaurant			
Is the Use permitted or permitted subject to criteria as set out in the development permit by-law and how have the applicable criteria have been addressed?			
USE PERMITTED			
Is a variation requested? Demonstrate how the proposed variation meets the criteria as set out in the development permit by-law.			
Abutting Land Use(s):			
RESIDENTIAL / COMMERCIAL			
Is the Development to be phase?		<input type="checkbox"/> Yes	<input type="checkbox"/> No
What is the anticipated date of construction?		SPRING 2023	
Is the land to be divided in the future?		UNKNOWN	
Are there any easements, right-of-ways or restrictive covenants affecting the subject land?		<input type="checkbox"/> Yes	<input checked="" type="checkbox"/> No
Plan Details:			
SEE SITE PLAN & ELEVATIONS			
<input type="checkbox"/> Residential	<input checked="" type="checkbox"/> Commercial	<input type="checkbox"/> Industrial	<input type="checkbox"/> Institutional
Lot Area:	Building Coverage:	Landscape Coverage:	
0.67 AC (sq.m)	10 (%) 283 (sq.m)	CB	
Building Height:	No. of Storeys:	No. of Units:	Method of Garbage Storage:
	1	X	Existing
Parking Surface:	Number of Parking Spaces:	Dimensions of Parking Spaces:	Number of Accessible Spaces:
Existing: Asphalt Proposed:	Existing: Proposed: Total: 29	6m x 3m	2
Loading Spaces:	Number of Loading Spaces:	Dimensions of Loading Spaces:	Other:
3.3m x 10m	1		
Heritage Tourist Inn/Bed and Breakfast:			
Is this an application for a Heritage Tourist Inn?	Number of Guest Rooms:	Is this an application for a Bed and Breakfast?	Number of Guest Rooms:
<input type="checkbox"/> Yes <input type="checkbox"/> No	<input type="checkbox"/> 1 <input checked="" type="checkbox"/> 2 <input type="checkbox"/> 3 <input type="checkbox"/> 4 <input type="checkbox"/> 5 <input type="checkbox"/> 6 <input type="checkbox"/> Other	<input type="checkbox"/> Yes <input type="checkbox"/> No	<input type="checkbox"/> 1 <input type="checkbox"/> 2 <input type="checkbox"/> 3 <input type="checkbox"/> Other
A Heritage Tourist Inn will require a Heritage Resource Assessment evaluating the heritage significance of the property including a description of historic features is required with the submission of this application.			

EXISTING BUILDINGS:		Building 1	Building 2
SEE SITE PLAN	Type of Structure		
	Date Constructed:		
	Front Line Setback:		
	Rear Lot Line Setback:		
	Side Lot Line Setback:		
	Side Lot Line Setback:		
	Height:		
	Dimensions:		
Floor Area:			
PROPOSED BUILDINGS:		Building 1	Building 2
N/A	Type of Structure:		
	Proposed Date of Construction:		
	Front Line Setback:		
	Rear Lot Line Setback:		
	Side Lot Line Setback:		
	Side Lot Line Setback:		
	Height:		
	Dimensions:		
Floor Area:			
Attached Additional Page, if necessary			

Access:

Municipal Street Unopen Road Allowance Existing Right-of-way Other _____

Name of Street/Road: KING ST + JAMES ST.

Entrance Approvals and Permit Number(s): NOT REQUIRED.

If the application will result in the creation of a new private road, a request for street naming will have to be submitted in conjunction with this application, to be approved by Council.

Water Access (where access to the subject land is by water only)

Docking Facilities (specify)	Parking Facilities (specify)
distance from subject land _____	distance from subject land _____
distance from nearest public road _____	distance from nearest public road _____

Services:

Municipal Water and Sewer Municipal Water & Private Sewage Private Well and Municipal Sewage Private Well and Private Sewage

Water and Sewer Hook-up Approvals and Permit Number(s):

AUTHORIZATION BY OWNER

I/We, the undersigned being the owner(s) of the subject land of this application for a consent, hereby authorize Jeff Brown (print name) to be the applicant in the submission of this application. Furthermore, I/we, being the registered owner(s) of the subject lands, hereby authorize the Members of Council, Planning Advisory Committee and the Town of Gananoque staff members, to enter upon the property for the purposes of conducting a site inspection with respect to the attached application.

[Signature] _____
Signature of Owner

Signature of Witness (not applicant)

Date

CONSENT BY OWNER

Complete the consent of the owner concerning personal information set out below.

I/We, _____, am/are the registered owner(s) of the land that is the subject of this application for Development Purposes and for purposes of the Municipal Freedom of Information and Protection of Privacy Act. I/We hereby authorize the use, or disclosure, to any person or public body, of any personal information collected under the authority of the Planning Act of the purpose of processing this application.

Signature of Owner

Signature of Owner

Signature of Witness (not applicant)

Date

DECLARATION OF APPLICANT

I, Jeff Brown of the TOWN of BANANOQUE in the PROVINCE of ONTARIO solemnly declare that:

I understand that the applicant/owner will be required to provide 100% security of the outside works in the form of a Letter of Credit or Certified Cheque until such time as the works are completed. A 15% holdback will be maintained for a period of one year after the works are completed. This will be applicable at the time of agreement.

Furthermore, I, being the applicant of the subject lands, hereby authorize the Members of Council, Planning Advisory Committee and the Town of Gananoque staff members, to enter upon the property for the purpose of conducting a site inspection with respect to the attached application.

All of the above statements contained in the application are true and I make this solemn declaration conscientiously believing it to be true and knowing that it is of the same force and effect as if made under Oath and by virtue of *The Canada Evidence Act*.

Declared/Sworn before me at Town of Gananoque this 15th day of February, 2023

Signature of a Commissioner, etc

[Signature]
Signature of Applicant

Office Use Only:		Roll No: <u>620 28000</u>
Official Plan Designation: <u>General Commercial</u>	Development Permit Designation: <u>Progressive Commercial</u>	Other:
Access (Entrance Permits etc): <u>n/a</u>	Water and Sewer Hookup (Permits etc):	Other:
Other Concurrent Applications: <input type="checkbox"/> Cash-in-Lieu of Parking <input type="checkbox"/> Condominium Approval <input type="checkbox"/> Consent/Severance	<input type="checkbox"/> Official Plan Amendment <input type="checkbox"/> Subdivision Approval	
Date Application Received: <u>Feb 15/2023</u>	Date Application Deemed Complete: <u>Feb 2023</u>	Fees Received: <u>Feb 15/2023</u>

For additional details please contact: Brenda Guy, Manager of Community Development
Town of Gananoque, 30 King Street East, Box 100, Gananoque, ON K7G 2T6
Telephone: (613) 382-2149 ext.126 Fax: (613) 382-8587 E-mail: bguy@townofgananoque.ca

STATISTICS	
LEGAL DESCRIPTION	PART OF LOT 15 PART 2 TOWN OF GANANOQUE COUNTY OF LEEDS
PARKING PROVIDED	21 STALLS
PARKING REQUIRED	21 STALLS
BUILDING AREA	3045 SQ.FT. (283 SQ.M)
PROPERTY AREA	24,831 SQ.FT.
QUEUING	12
ALL SITE SERVICES AS EXISTING ALL SITE STORM DRAINAGE AS EXISTING	

LEGEND	
	PROPERTY LINE
	TRAFFIC DIRECTION
	LIGHT STANDARD
	ENTRANCE/EXIT
	GRASS
	SHRUB BED
	CONCRETE
	ASPHALT PAVING
	SURFACE PARKING
	EX. SHRUB
	EX. TREE
	BARRIER FREE PARKING

DO NOT SCALE DRAWINGS
CHECK AND VERIFY ALL DIMENSIONS BEFORE PROCEEDING WITH THE WORK.
THESE DRAWINGS HAVE BEEN DESIGNED IN CONFORMANCE WITH THE ONTARIO BUILDING CODE.

Revisions and Issues		
REV.	DATE	DESCRIPTION
1	2023.02.07	ISSUED FOR MUNICIPAL REVIEW
2		
3		

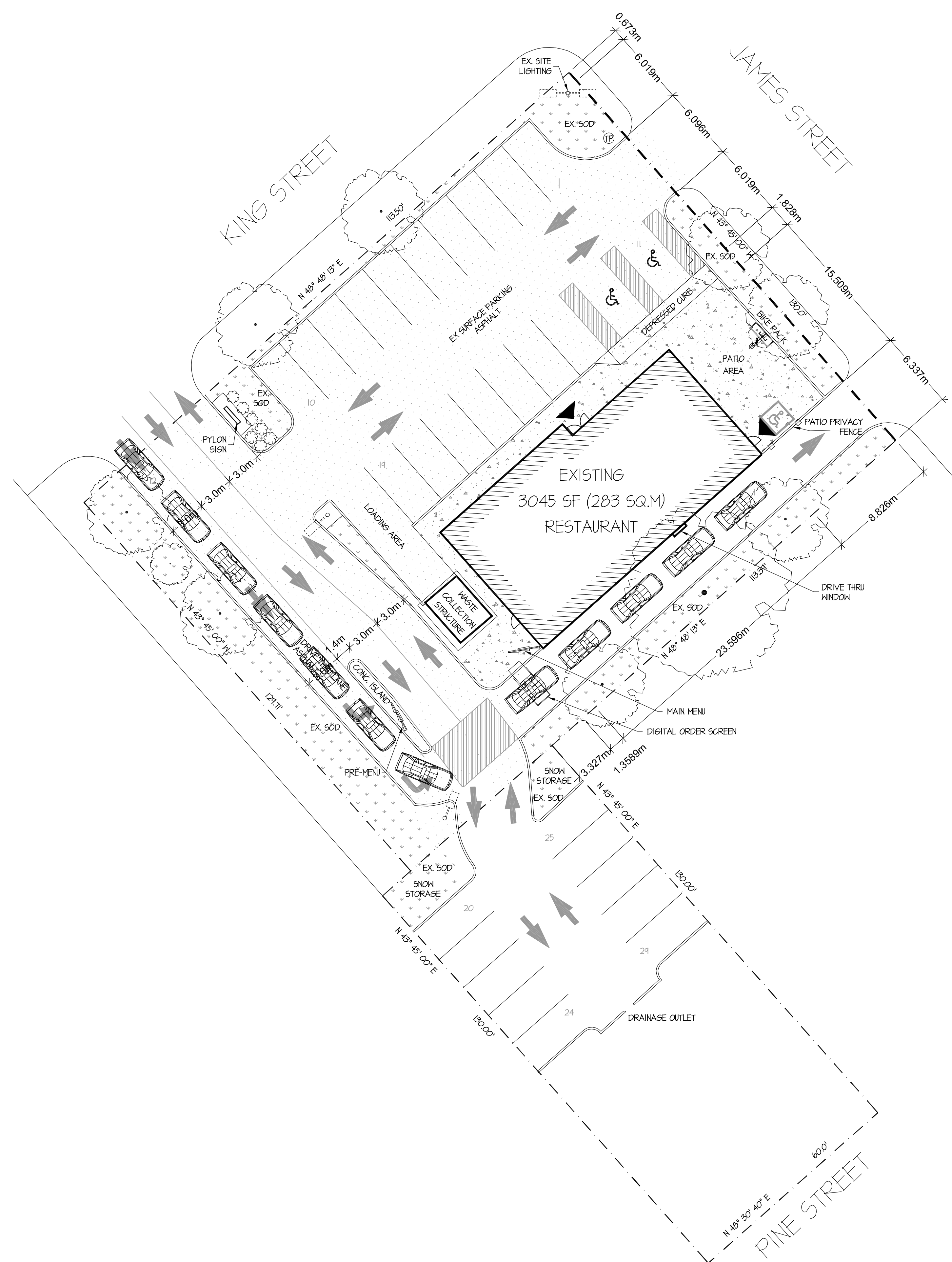

Stamp

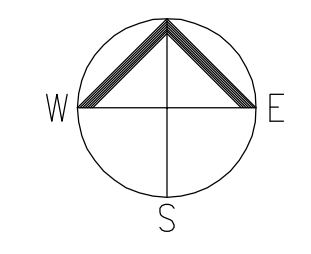

Project

**POPEYES CHICKEN
FOR GANANOQUE**

399 KING ST E
GANANOQUE, ON
Drawing

**SITE DEVELOPEMENT
PLAN**

Drawn By	JMJ	Checked By	
Scale	1 : 200	Date	FEB 2023
Project No.	94-1076	Revision	1
Drawing No.	SP01		

THESE DRAWINGS WERE PREPARED FOR BUILDING PERMITS AND AS A GENERAL CONSTRUCTION GUIDE. DO NOT SCALE DRAWINGS. SITE CONDITIONS SHALL RULE. DETAILS MAY CHANGE AFTER HIDDEN CONDITIONS ARE REVEALED. ANY MAJOR DISCREPANCIES WHICH ARE EXPOSED AFTER DEMOLITION SHALL BE REPORTED TO THE OWNERS REPRESENTATIVES. ALL CONTRACTORS AND/OR TRADES SHALL VERIFY ALL DIMENSIONS, NOTES, DRAWINGS, AND SPECIFICATIONS ON THE SITE AND REPORT ANY DISCREPANCIES TO THE DESIGNER PRIOR TO THE COMMENCEMENT OF WORK. ALL DRAWINGS, PRINTS, AND ANY RELATED DOCUMENTS ARE THE PROPERTY OF "VERDICT DESIGN" AND MUST BE RETURNED UPON REQUEST. REPRODUCTION OF THESE DRAWINGS AND ANY RELATED DOCUMENTS IN PART OR IN WHOLE IS STRICTLY FORBIDDEN WITHOUT THE WRITTEN CONSENT OF "VERDICT". THESE DRAWINGS ARE TO BE USED FOR THE PURPOSE FOR WHICH THEY WERE ISSUED.

"VERDICT DESIGN" WILL NOT ASSUME RESPONSIBILITY FOR THE EXTENT OF THE CONTRACT BETWEEN THE OWNER AND/OR THE OWNERS REPRESENTATIVE, AND THE CONTRACTORS AND/OR INDIVIDUAL TRADES. THIS INCLUDES ANY WORK, LABOUR, MATERIALS ETC. RELATED OR NOT RELATED TO THESE DRAWINGS FOR THE COMPLETION OF THE PROJECT.

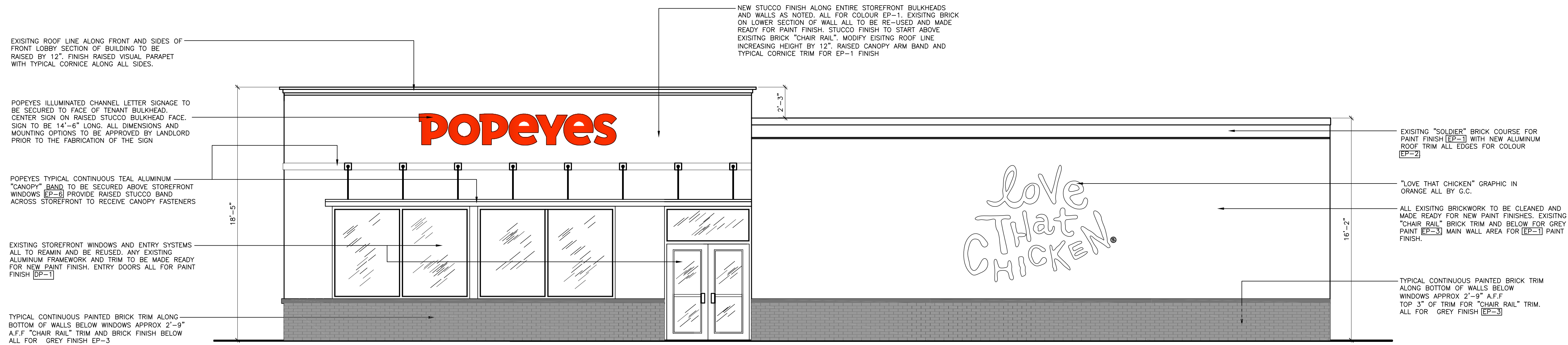

1 PARKING SIDE EXTERIOR ELEVATION
SCALE 1/4" = 1'-0"

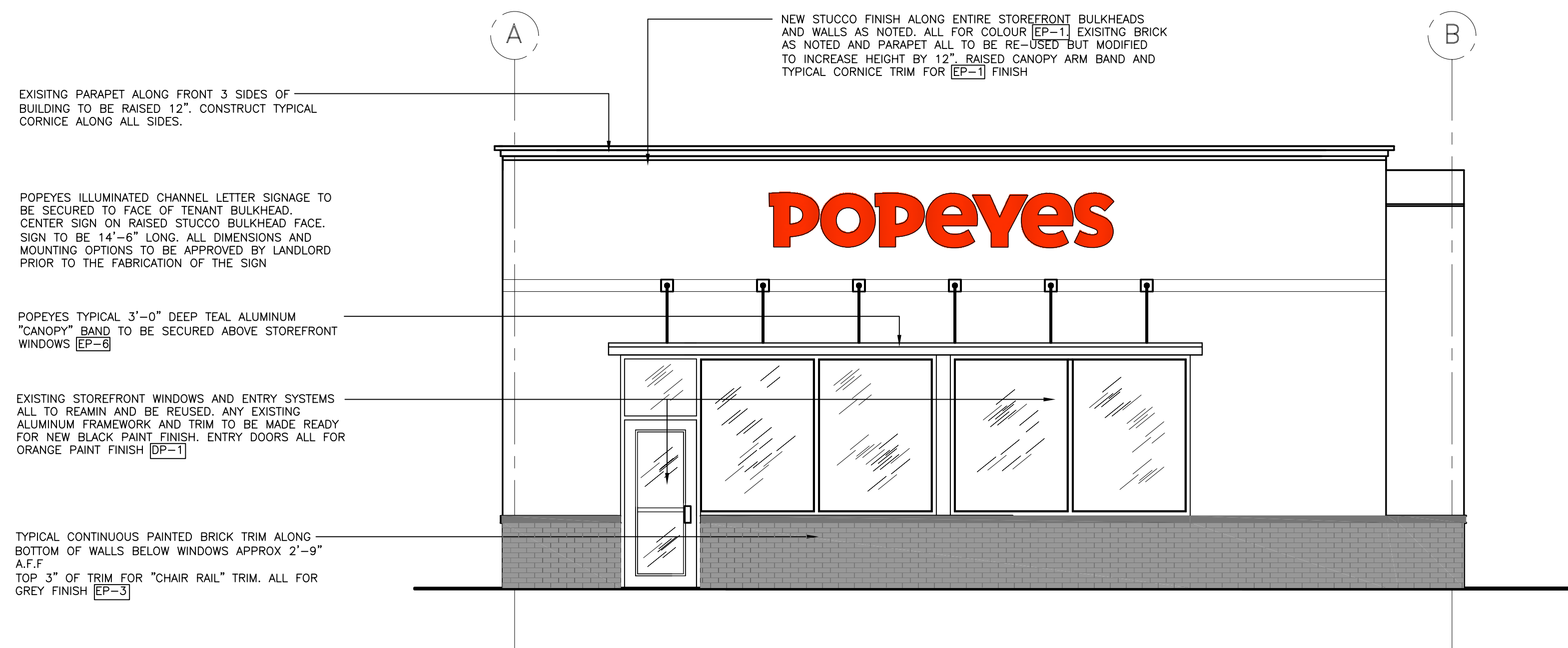

2 FRONT EXTERIOR ELEVATION
SCALE 1/4" = 1'-0"

CODE	MATERIAL	LOCATION	SOURCE	PRODUCT	COLOUR	DIMENSION	ADDITIONAL INFORMATION
EB-1	FACE BRICK	ACCENT TOWER BRICK	NICHHA FIBER CEMENT	VINTAGE BRICK	ALEXANDRIA BUFF	7 1/2" x 2 1/2" x 2"	CONTACT: MATT STEPHENSON M: 770.789.8228 POPEYES@NICHHA.COM
			ALTERNATE OPTION: CREATIVE MATERIALS CORPORATION	ALTERNATE OPTION: THIN BRICK	FLAGSTAFF	8 1/2" x 2 1/2" x 3/4"	CONTACT: POPEYESTILES@CREATIVEMATERIALSCORP.COM 1.800.207.2967 EXT. 7797
EF-1	EXTERIOR WOOD SIDING	FRONT FACADE EXTERIOR WALLS	NICHHA FIBER CEMENT	VINTAGE WOOD AWP 3030	CEDAR	17 1/2" x H x 119 1/2" L	CONTACT: MATT STEPHENSON M: 770.789.8228 POPEYES@NICHHA.COM
EP-1	EXTERIOR PAINT	MAIN WALL SURFACE ABOVE WAINSCOT ACCENT TRIM	BENJAMIN MOORE	ULTRA SPEC 500 EGGSHELL	WHITE OC-125 MOONLIGHT WHITE		CONTACT: RODGER LIPPMAN C: 848.702.0239 RODGER.LIPPMAN@BENJAMINMOORE.COM
EP-2	EXTERIOR PAINT	BRICK TOWER METAL COPING	BENJAMIN MOORE		ROOT BEER CANDY 2105-20		CONTACT: RODGER LIPPMAN C: 848.702.0239 RODGER.LIPPMAN@BENJAMINMOORE.COM
EP-3	EXTERIOR PAINT	EXTERIOR WAINSCOT, SILL PAINT AND DUMPSTER WALLS	BENJAMIN MOORE	ULTRA SPEC 500 EGGSHELL	"GRAY" HC-170 STONINGTON GREY		CONTACT: RODGER LIPPMAN C: 848.702.0239 RODGER.LIPPMAN@BENJAMINMOORE.COM
EP-4	EXTERIOR PAINT	BOLLARDS, PYLON POLE AND DIRECTIONAL SIGN POLES	BENJAMIN MOORE	SAFETY YELLOW			CONTACT: RODGER LIPPMAN C: 848.702.0239 RODGER.LIPPMAN@BENJAMINMOORE.COM
EP-5	METAL PAINT	DRIVE-THRU WINDOW CANOPY	PROVIDED BY MANUFACTURER	PROVIDED BY MANUFACTURER	ORANGE PANTONE #3564-C PROVIDED BY MANUFACTURER		PROVIDED BY MANUFACTURER
EP-6	METAL PAINT	BUILDING CANOPIES	PROVIDED BY MANUFACTURER	PROVIDED BY MANUFACTURER	TEAL PANTONE #326-C PROVIDED BY MANUFACTURER		PROVIDED BY MANUFACTURER
EP-7	EXTERIOR PAINT	DUMPSTER GATES	BENJAMIN MOORE		FACTORY FINISH BLACK		CONTACT: RODGER LIPPMAN C: 848.702.0239 RODGER.LIPPMAN@BENJAMINMOORE.COM
EP-8	EXTERIOR PAINT	ALL EXTERIOR WALLS	BENJAMIN MOORE	ALIPHATIC ACRYLIC URETHANE - CLEAR GLOSS	ANTI-GRAFFITI PAINT M74-00/M75 2 COATS ON FULL FACADE		CONTACT: RODGER LIPPMAN C: 848.702.0239 RODGER.LIPPMAN@BENJAMINMOORE.COM
DP-1	DOOR	EXTERIOR DOORS: MAIN ENTRANCE AND SIDE ENTRANCE	PROVIDED BY MANUFACTURE	TO BE PURCHASED FROM MANUFACTURER IN ORANGE FINISH	ORANGE PANTONE #3564-C PROVIDED BY MANUFACTURER		PROVIDED BY MANUFACTURER

Revisions

VERDICT:DESIGN

76 HASTINGS AVE., Toronto, Ontario, M4L 2L2
Tel: (416) 536-9752
e-mail: verdict@rogers.com

Client

POPEYES
LOUISIANA RESTAURANT

Project

399 KING ST. E
GANANOQUE, ON
K7G 1G6

Drawing
EX. ELEVATION (1)
Scale AS NOTED
Date DECEMBER 2022
Drawing No. A9

The undersigned has reviewed and takes full responsibility for this design, and has the qualifications and meets the requirements set out in the Ontario Building Code to be a designer.

QUALIFICATION INFORMATION
Required unless design is exempt under 2.17.4.3.(5) of the building code
KATHLEEN WHITE 26023
NAME SIGNATURE BCIN

REGISTRATION INFORMATION
Required unless design is exempt under 2.17.4.7 of the building code
VERDICT:DESIGN 32632
FIRM NAME BCIN

THESE DRAWINGS WERE PREPARED FOR BUILDING PERMITS AND AS A GENERAL CONSTRUCTION GUIDE. DO NOT SCALE DRAWINGS. SITE CONDITIONS SHALL RULE. DETAILS MAY CHANGE AFTER HIDDEN CONDITIONS ARE REVEALED. ANY MAJOR DISCREPANCIES WHICH ARE EXPOSED AFTER DEMOLITION SHALL BE REPORTED TO THE OWNERS REPRESENTATIVES. ALL CONTRACTORS AND/OR TRADES SHALL VERIFY ALL DIMENSIONS, NOTES, DRAWINGS, AND SPECIFICATIONS ON THE SITE AND REPORT ANY DISCREPANCIES TO THE DESIGNER PRIOR TO THE COMMENCEMENT OF WORK. ALL DRAWINGS, PRINTS, AND ANY RELATED DOCUMENTS ARE THE PROPERTY OF "VERDICT DESIGN" AND MUST BE RETURNED UPON REQUEST. REPRODUCTION OF THESE DRAWINGS AND ANY RELATED DOCUMENTS IN PART OR IN WHOLE IS STRICTLY FORBIDDEN WITHOUT THE WRITTEN CONSENT OF "VERDICT". THESE DRAWING ARE TO BE USED FOR THE PURPOSE FOR WHICH THEY WERE ISSUED. "VERDICT DESIGN" WILL NOT ASSUME RESPONSIBILITY FOR THE EXTENT OF THE CONTRACT BETWEEN THE OWNER AND/OR THE OWNERS REPRESENTATIVE, AND THE CONTRACTORS AND/OR INDIVIDUAL TRADES. THIS INCLUDES ANY WORK, LABOUR, MATERIALS ETC. RELATED OR NOT RELATED TO THESE DRAWINGS FOR THE COMPLETION OF THE PROJECT.

EXISTING "SOLDIER" BRICK COURSE FOR PAINT FINISH [EP-1] WITH NEW ALUMINUM ROOF TRIM ALL EDGES

TYPICAL GRAPHIC PANELS SECURED TO FACE OF PAINTED BRICK. PANELS TO BE SUPPLIED BY POPEYES, INSTALLED BY LANDLORD

ALL EXISTING BRICKWORK TO BE CLEANED AND MADE READY FOR NEW PAINT FINISHES. EXISTING "CHAIR RAIL" AND BELOW FOR GREY PAINT [EP-3] MAIN WALL AREA FOR [EP-1] PAINT FINISH.

TYPICAL CONTINUOUS PAINTED BRICK TRIM ALONG BOTTOM OF WALLS BELOW WINDOWS APPROX 2'-9" A.F.F. TOP 3" OF TRIM FOR "CHAIR RAIL" TRIM. ALL FOR GREY FINISH [EP-3]

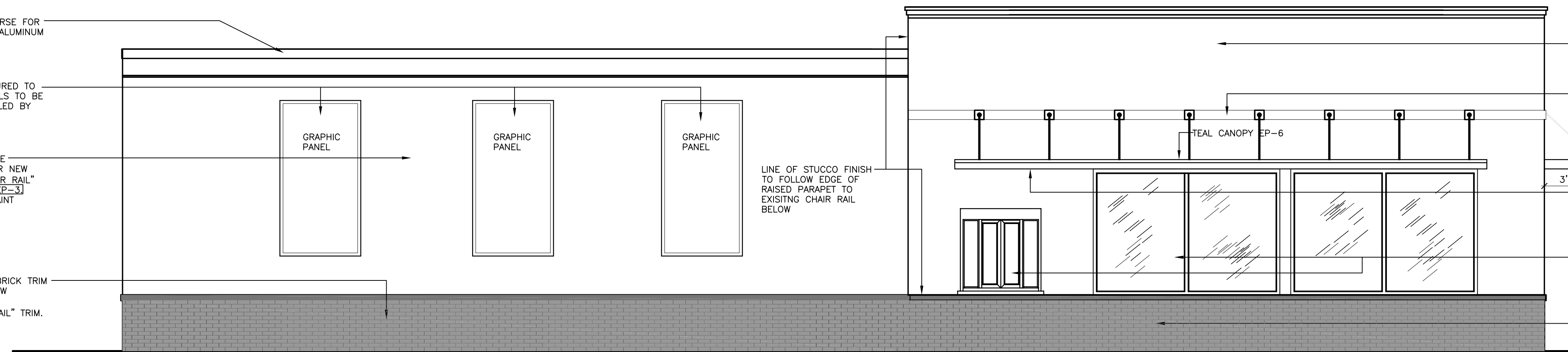

FACE OF STOREFRONT WALL AND NEW RAISED PARAPET ALL FOR NEW STUCCO FINISH [EP-1] STUCCO FINISH FROM TOP OF EXISTING BRICK "CHAIR RAIL"

PROVIDE CONTINUOUS 1" RAISED STUCCO DETAIL ACROSS STOREFRONT BEHIND ANGLED CANOPY FASTENERS. [EP-1]

TEAL CANOPY EP-6

POPEYES TYPICAL CONTINUOUS TEAL ALUMINUM "CANOPY" TO BE INSTALLED ABOVE DRIVE-THRU AND LOBBY WINDOWS. FINISH [EP-9]

EXISTING STOREFRONT WINDOWS TO REMAIN AS IS. NEW DRIVE-THRU WINDOW TO BE INSTALLED. ALL EXISTING ALUMINUM FRAMEWORK AND TRIM TO BE MADE READY FOR NEW BLACK PAINT FINISH. [EP-7]

TYPICAL CONTINUOUS PAINTED BRICK TRIM ALONG BOTTOM OF WALLS BELOW WINDOWS APPROX 2'-9" A.F.F. TOP 3" OF TRIM FOR "CHAIR RAIL" TRIM. ALL FOR GREY FINISH [EP-3]

3 DRIVE-THRU ELEVATION
SCALE 1/4" = 1'-0"

EXISTING "SOLDIER" BRICK COURSE FOR PAINT FINISH [EP-1] WITH NEW ALUMINUM ROOF TRIM ALL EDGES

ALL EXISTING BRICKWORK TO BE CLEANED AND MADE READY FOR NEW PAINT FINISHES. EXISTING "CHAIR RAIL" AND BELOW FOR GREY PAINT [EP-3] MAIN WALL AREA FOR [EP-1] PAINT FINISH.

EXISTING REAR DOOR TO STORAGE ALL TO REMAIN AND BE REUSED. ALL FOR PAINT FINISH [EP-3]

TYPICAL CONTINUOUS PAINTED BRICK TRIM ALONG BOTTOM OF WALLS BELOW WINDOWS APPROX 2'-9" A.F.F. TOP 3" OF TRIM FOR "CHAIR RAIL" TRIM. ALL FOR GREY FINISH [EP-3]

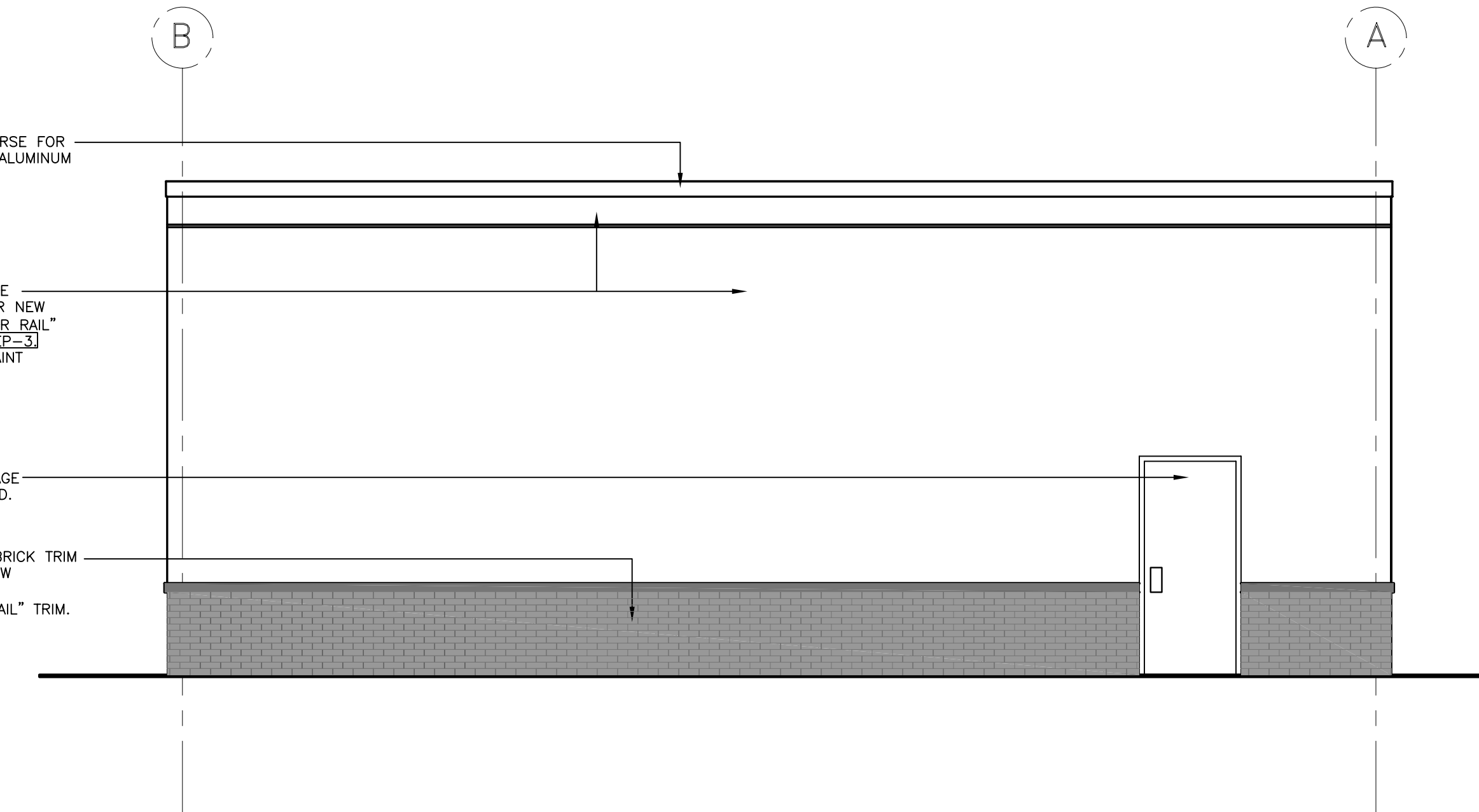

4 REAR EXTERIOR ELEVATION
SCALE 1/4" = 1'-0"

CODE	MATERIAL	LOCATION	SOURCE	PRODUCT	COLOUR	DIMENSION	ADDITIONAL INFORMATION
EB-1	FACE BRICK	ACCENT TOWER BRICK	NICHHA FIBER CEMENT	VINTAGE BRICK	ALEXANDRIA BUFF	7 7/8" x 2 1/4" x 3/4"	CONTACT: MATT STEPHENSON M: 770.789.8228 POPEYES@NICHHA.COM
			ALTERNATE OPTION: CREATIVE MATERIALS CORPORATION	ALTERNATE OPTION: THIN BRICK	FLAGSTAFF	8 1/2" x 2 1/4" x 3/4"	CONTACT: POPEYESTILE@CREATIVEMATERIALSCORP.COM 1.800.207.2967 EXT. 7797
EF-1	EXTERIOR WOOD SIDING	FRONT FACADE EXTERIOR WALLS	NICHHA FIBER CEMENT	VINTAGE WOOD AWP 3030	CEDAR	17 7/8" x H119 1/2" L	CONTACT: MATT STEPHENSON M: 770.789.8228 POPEYES@NICHHA.COM
EP-1	EXTERIOR PAINT	MAIN WALL SURFACE ABOVE WAINSCOT ACCENT TRIM	BENJAMIN MOORE	ULTRA SPEC 500 EGGSHELL	WHITE OC-125 MOONLIGHT WHITE		CONTACT: RODGER LIPPMAN C: 848.702.0239 RODGER.LIPPMAN@BENJAMINMOORE.COM
EP-2	EXTERIOR PAINT	BRICK TOWER METAL COPING	BENJAMIN MOORE		ROOT BEER CANDY 2105-20		CONTACT: RODGER LIPPMAN C: 848.702.0239 RODGER.LIPPMAN@BENJAMINMOORE.COM
EP-3	EXTERIOR PAINT	EXTERIOR WAINSCOT, SILL PAINT AND DUMPSTER WALLS	BENJAMIN MOORE	ULTRA SPEC 500 EGGSHELL	"GRAY" HC-170 STONINGTON GREY		CONTACT: RODGER LIPPMAN C: 848.702.0239 RODGER.LIPPMAN@BENJAMINMOORE.COM
EP-4	EXTERIOR PAINT	BOLLARDS, PYLON POLE AND DIRECTIONAL SIGN POLES	BENJAMIN MOORE	SAFETY YELLOW			CONTACT: RODGER LIPPMAN C: 848.702.0239 RODGER.LIPPMAN@BENJAMINMOORE.COM
EP-5	METAL PAINT	DRIVE-THRU WINDOW CANOPY	PROVIDED BY MANUFACTURER	PROVIDED BY MANUFACTURER	ORANGE PANTONE #3564-C PROVIDED BY MANUFACTURER		PROVIDED BY MANUFACTURER
EP-6	METAL PAINT	BUILDING CANOPIES	PROVIDED BY MANUFACTURER	PROVIDED BY MANUFACTURER	TEAL PANTONE #326-C PROVIDED BY MANUFACTURER		PROVIDED BY MANUFACTURER
EP-7	EXTERIOR PAINT	DUMPSTER GATES	BENJAMIN MOORE		FACTORY FINISH BLACK		CONTACT: RODGER LIPPMAN C: 848.702.0239 RODGER.LIPPMAN@BENJAMINMOORE.COM
EP-8	EXTERIOR PAINT	ALL EXTERIOR WALLS	BENJAMIN MOORE	ALIPHATIC ACRYLIC URETHANE - CLEAR GLOSS	ANTI-GRAFFITI PAINT M74-00/M75 2 COATS ON FULL FACADE		CONTACT: RODGER LIPPMAN C: 848.702.0239 RODGER.LIPPMAN@BENJAMINMOORE.COM
DP-1	DOOR	EXTERIOR DOORS: MAIN ENTRANCE AND SIDE ENTRANCE	PROVIDED BY MANUFACTURE	TO BE PURCHASED FROM MANUFACTURER IN ORANGE FINISH	ORANGE PANTONE #3564-C PROVIDED BY MANUFACTURER		PROVIDED BY MANUFACTURER

Revisions
VERDICT:DESIGN
76 HASTINGS AVE., Toronto, Ontario, M4L 2L2
Tel: (416) 536-9752
e-mail: verdict@rogers.com

Client
POPEYES
LOUISIANA HOTWINGS

Project
399 KING ST. E
GANANOQUE, ON
K7G 1G6

Drawing
EX. ELEVATION (2)
Scale
AS NOTED
Date
DECEMBER 2022
Drawing No.
A10

The undersigned has reviewed and takes full responsibility for this design, and has the qualifications and meets the requirements set out in the Ontario Building Code to be a designer.

QUALIFICATION INFORMATION
Required unless design is exempt under 2.17.4.3.(5) of the building code
KATHLEEN WHITE 26023
NAME SIGNATURE BCIN

REGISTRATION INFORMATION
Required unless design is exempt under 2.17.4.7 of the building code
VERDICT:DESIGN 32632
FIRM NAME BCIN



TAMPER RESISTANT SECURITY MACHINE SCREWS TO HOLD BACKS TO CABINET

ROTATION 15° LEFT TO RIGHT

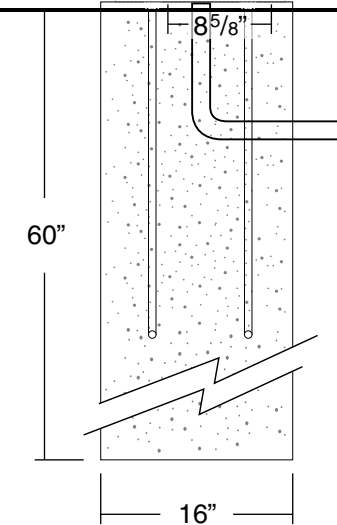
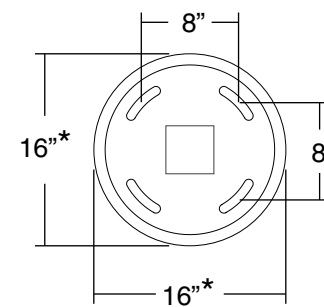
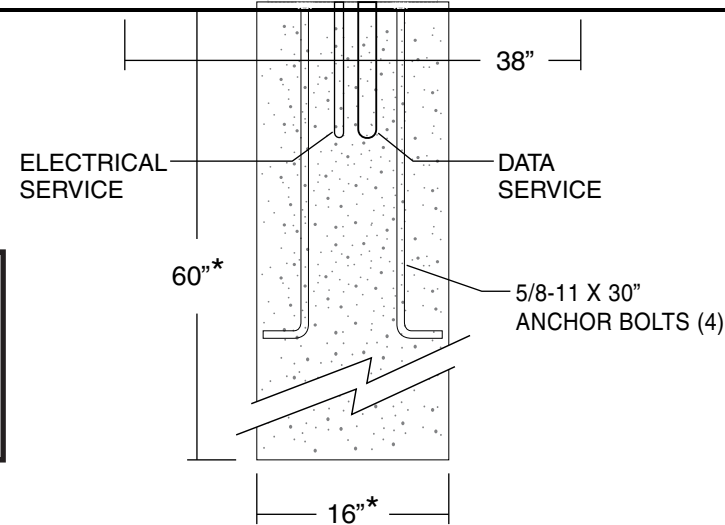
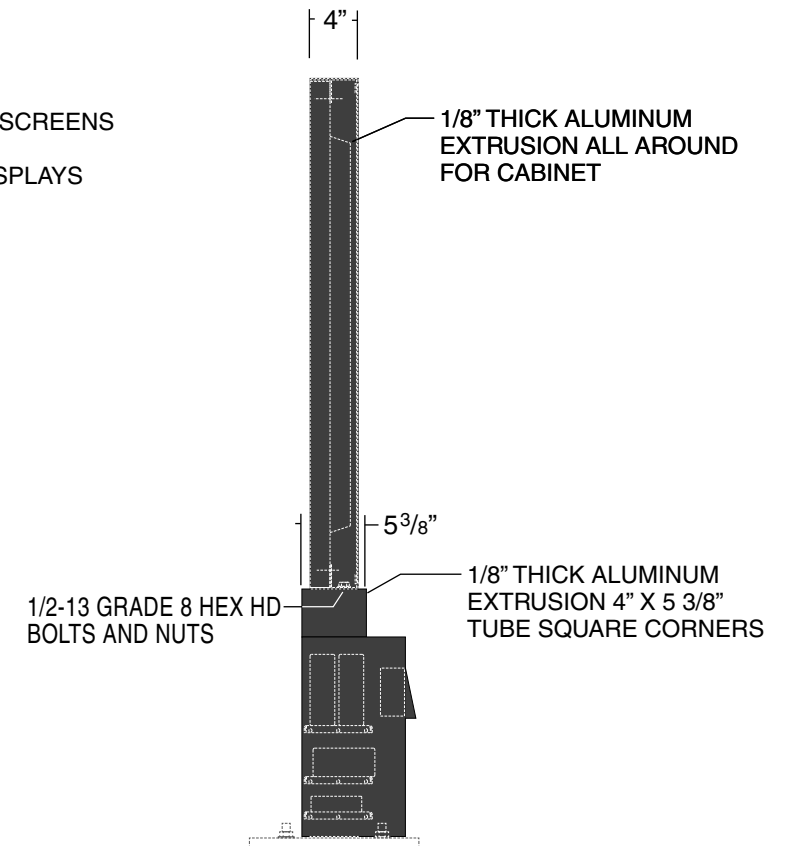
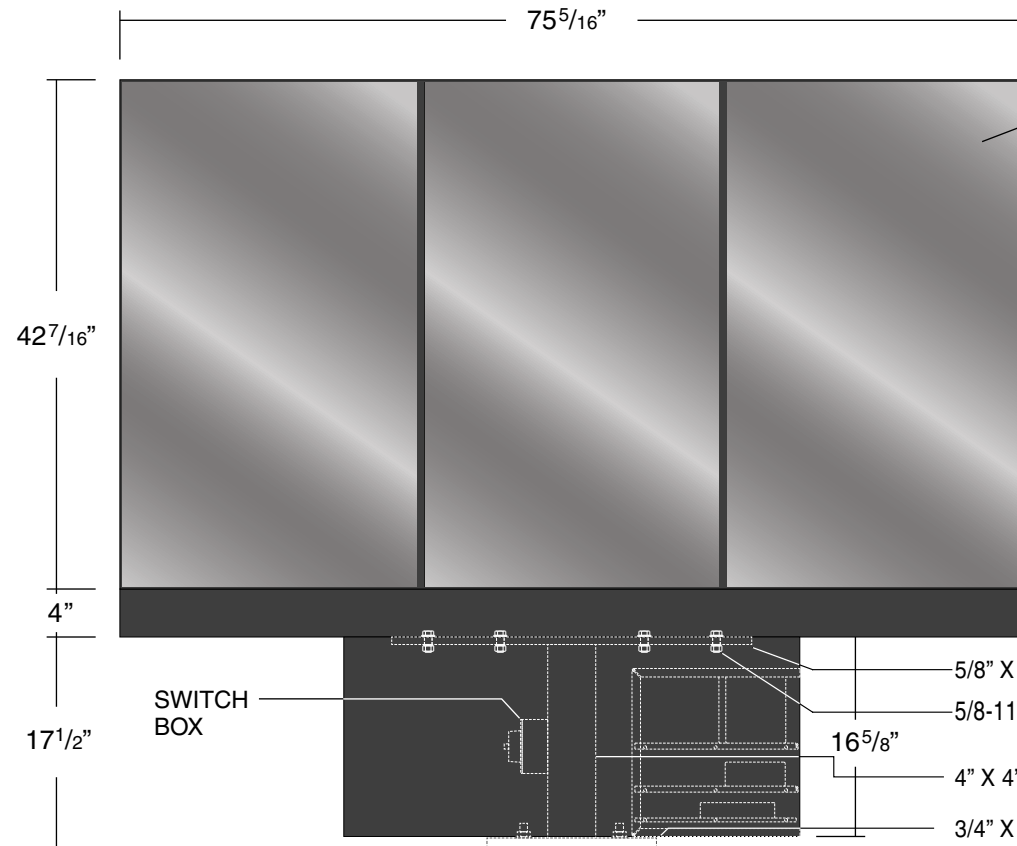
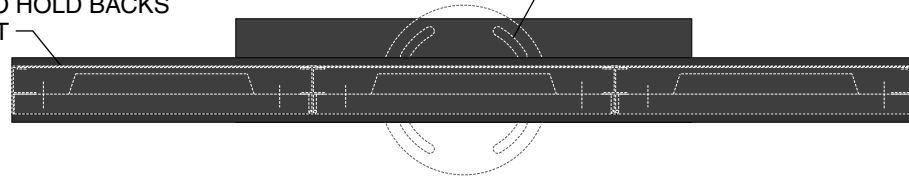

*** These are approximate foundation measurements.**
The soil bearing capacity at the erection site must be considered when designing the foundation. The sign manufacturer is not able to predetermine the specific needs of each location. Consult a local engineer for design specifications.

Electrical:
13.5 Amps @ 120 VAC 60 Hz

Drawing Type Art Creative
Customer Popeyes Louisiana Kitchen
Project Description 1 X 3 Digital Drive-Thru

Drawn By: DL
Proj. Man.:
Date: 10/03/19
Proj. No.:

Note: 1) Housing Constructed of Aluminum Extrusion
2) Entire Board and Steel Powder Coat Black

MATERIALS: All Joints To Be Welded All Around
Grade A36 Steel Shapes
Grade A500 B Steel Tube





POPEYES®



DIGITAL MENU BOARD **INSTALLATION GUIDELINES**

Franchise Responsibilities & Requirements

IMPORTANT: FAILURE TO PROPERLY PREPARE YOUR SITE FOR YOUR DIGITAL MENU BOARD INSTALLATION COULD RESULT IN DELAYED INSTALLATION, IMPROPER FUNCTIONALITY, DIFFICULTY IN PROVISIONING, DAMAGED PRODUCT AND ADDITIONAL INSTALLATION FEES. PLEASE REVIEW THE ATTACHED INSTRUCTIONS IN DETAIL AND DIRECT ANY QUESTIONS TO

popeyes.orders@LSICORP.COM

NON LSI OBLIGATION

LSI Industries is not responsible for the following:

- Installing Data Cables from the building to the outdoor digital signage locations, terminated with rj45 males connectors
- Primary electrical power to the digital menu boards or presell
- Network Port configuration
- Network viability
- Any software/media player equipment supplied by third parties
- Installation of Microphone/Speaker Systems



Data Cables



Power

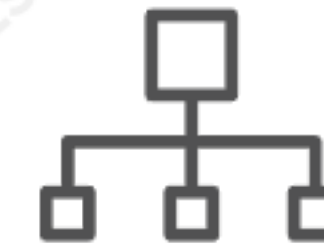

Network Configuration



Network Viability



Third Party Equipment



Third Party Software

SITE PREPARATION

Site Readiness Survey:

- After you've placed your order, and prior to installation, LSI will perform a "Site Readiness Survey". This will aid in confirming that the site is properly prepared for the new digital Menu board installation.
- LSI, GC and FZ to determine time of site readiness survey, which is typically conducted 7-10 days prior to installation.
- If site is not ready at the time of the survey, LSI will report remaining needs to FZ. Then, prior to finalizing the install schedule, the FZ will be required to provide photos confirming the remaining items have been completed or a return visit from the LSI tech to re-survey will be required at additional cost.
- If site is ready, LSI will confirm the install date.



Survey



Site Readiness



Install Date



Electrician

Franchise needs to have electrician onsite during LSI installation to make final electrical connections. All ODMB/IDMB equipment must be on site prior to the start of LSI's equipment installation.



LSI OBLIGATION

LSI Industries is responsible for the following:

- Install all digital menu board, presell screens and enclosures as ordered by franchisee on franchise pre-installed anchor bolts and foundations.
- Install LSI network switches, as required, for each installed digital display. Install Third party media players and network switches, as required, for each installed digital display.
- LSI to provide and install the CAT6 data cable for the indoor displays only. (LSI does not provide or install the outdoor cables.)
- Confirm that menu board screens are functioning and are on the correct input.
- Contacting Stratacache to confirm media players are functioning properly and that cabling is correct. Stratacache Support is responsible for confirming that pricing and content are accurate and integrated order confirmation is displaying.
- Equipment provisioning covers up to 1 hour of Software/Media player equipment setup time.
- Delays caused by faulty cables, equipment, network issues or caused by issues/conditions outside of LSI's control could result in additional hourly charges outlined on the following pages.



Shipping



Installation



Confirm Connectivity

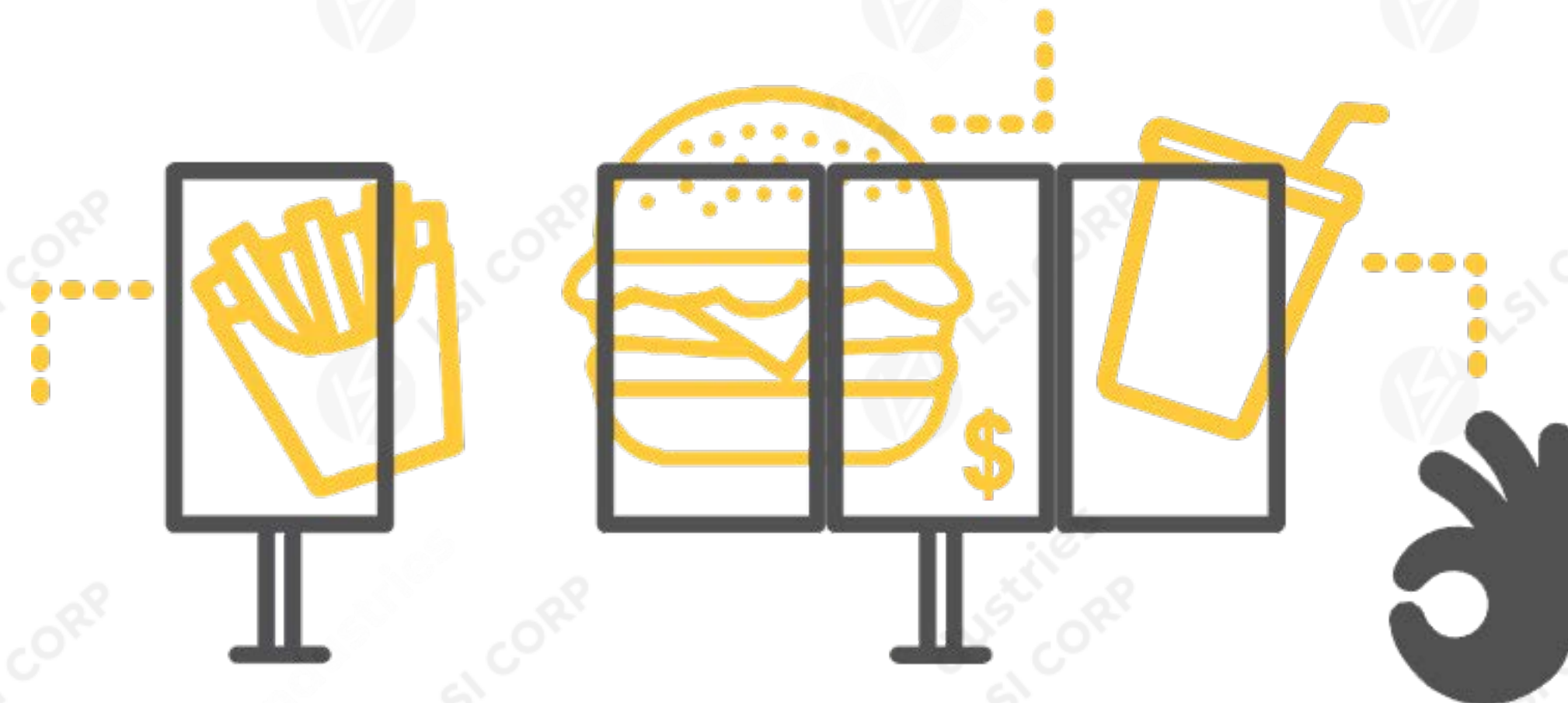

Confirm Display



FRANCHISE SITE INSTALL

Customer responsible for the following:

SHIPMENT RECEIPT: Customer to receive and store all equipment on site until installation.

Upon shipment receipt and BEFORE accepting the shipment, inspect all pallets/packages for damage and/or missing parts. Note any missing/damaged parts on billing of lading as "Visible Damage / Missing Parts Evident - Pending Inspection" Failure to note this on the bill of lading will prevent reimbursement through freight claims. A LSI-managed installation delay resulting from unreported damaged/missing equipment may result in additional installation charges.

SAMSUNG ELECTRICAL REQUIREMENTS: Properly tested electrical service to point of installation in dedicated conduit:

- For 1x3 ODMB: (1) dedicated 120v 15-amp circuit and (1) dedicated 120v 20-amp circuit to pedestal site.
- For 1x1 Presell: (1) dedicated 120v 15-amp circuit and (1) dedicated 120v 20-amp circuit to pedestal site.
- For Interior Digital Menu Boards: (1) dedicated 120v circuit with (1) duplex outlet per screen, located behind each digital screen location.

DATA CABLE REQUIREMENTS: Ensure proper data cables run to point of installation IN DEDICATED CONDUIT:

Shielded Cat6 cable is highly recommended Length of these Shielded Cat6A cables at the base of the Outdoor Menu Boards/Pre-Sells should be 6 ft or no more than 8 ft to ensure that connections can be easily made to the digital displays.

For 1x3 ODMB: run (4) dedicated Shielded Cat6A data cables and ensure they have been properly terminated with shielded RJ45 connectors and tested for continuity (2 cables per media player).

For 1x1 Presell: run (2) dedicated Shielded Cat6A data cables and ensure they have been properly terminated with shielded RJ45 connectors and tested for continuity.



Conduit
2" Minimum



Circuit

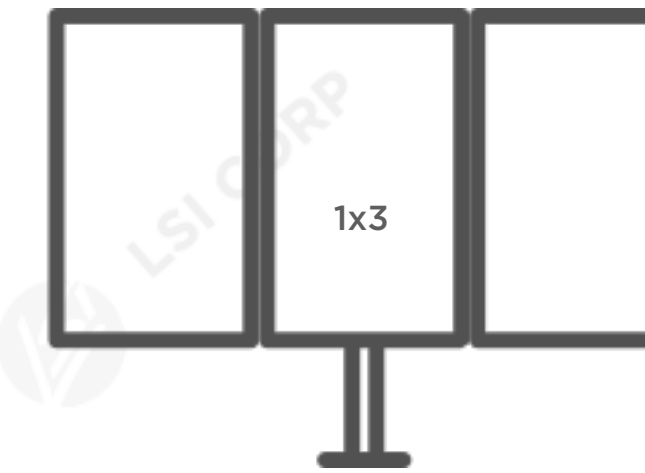
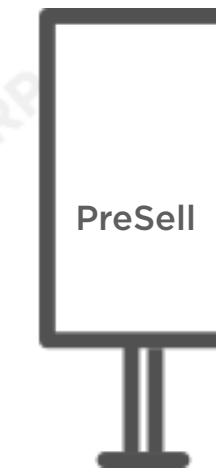

Minimum Space Requirements for IDMB Displays

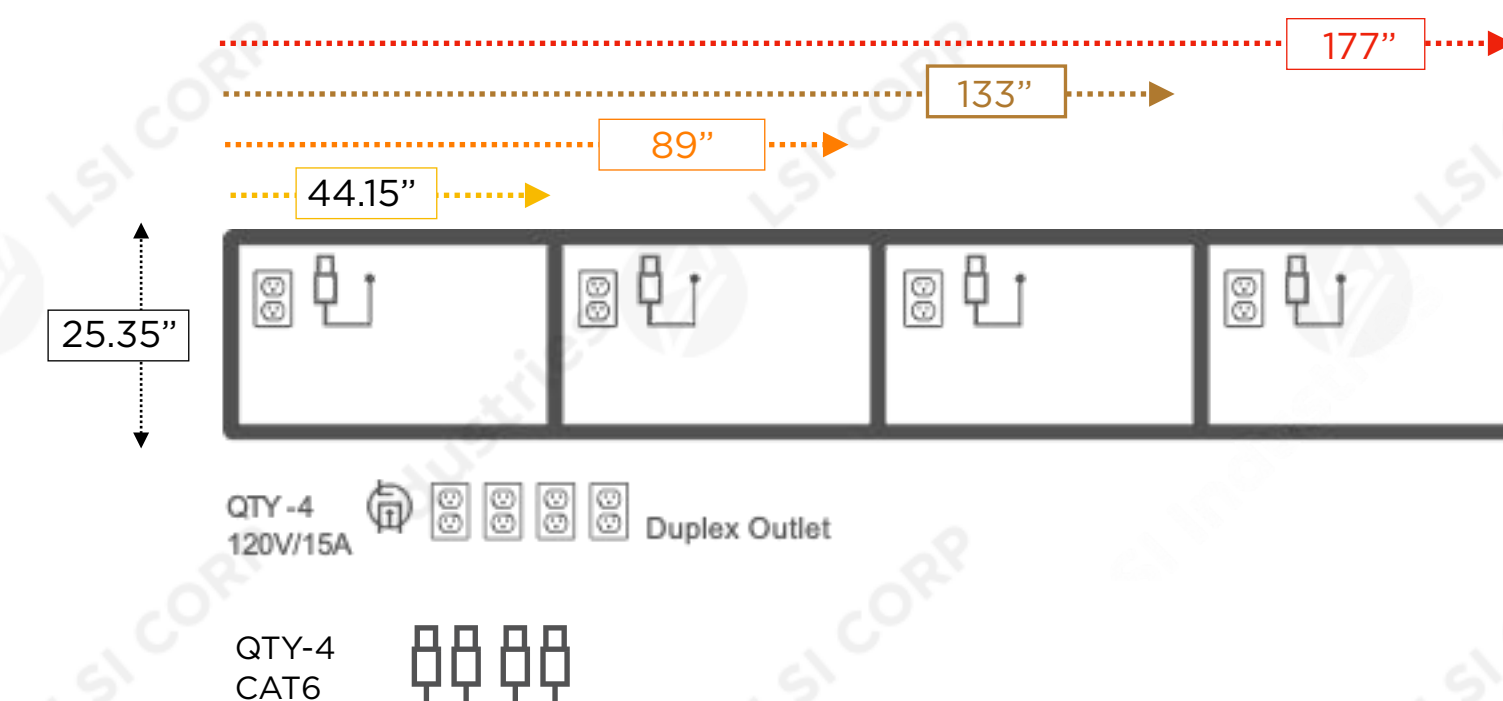

FRANCHISE SITE INSTALL (cont)

Customer responsible for the following:

PROPER ANCHOR BOLT PLACEMENT: Review 1x3 ODMB / 1x1 Digital PreSell instructions for proper setting

INTERIOR (IDMB)

– Standard installation is wall mount; Ceiling mounts will be an additional charge

EXTERIOR (ODMB, PRESELL)

- Must have primary electric live at each digital signage location prior to the scheduled LSI installation
- An electrician onsite to make all electrical connections to the pedestal and the computer equipment compartment at time of LSI installation
- Provide concrete foundation around conduits and the required anchor bolt pattern
- Active internet connection at the media player location
- Permanent power utilities from the street to the restaurant
- POS, Firewall and Network installed and configured to Stratacache network requirements
- Data connections to network and port configuration tested and working at menu board locations

REVIEW AND ACKNOWLEDGE COMPLETION OF DOCUMENTS IN YOUR ORDER CONFIRMATION EMAIL:

Requirements for a Successful Stratacache DMB Installation - POS, Firewall, Network instructions

Popeyes Rollout - Network Requirements

Stratacache Canopy Blocking and OCU Design - explains OCU functionality of 1x3 ODMB

LSI ODMB System - Site Readiness Instructions (this document)

COMPLETE THE NETWORK INFORMATION FORM:

<https://app.smartsheet.com/b/form/3f30102de8854f55ab97570878a12cec>

COMPLETE POPEYES-DIGITAL FRANCHISEE PRE-INSTALL CHECKLIST FORM:

<https://www.cognitofrms.com/LSI8/PopeyesDigitalFranchiseePreInstallChecklist>

Installation questions should go to popeyes.orders@lsicorp.com



Footer



Anchor Bolt Pattern



Power



Electrician



Network Configuration



Network Viability



POS



Confirm Connectivity



Customer responsible for the following:

INSTALLATION FEES FOR SITE DELAYS, REVISITS, CANCELLATIONS, AND RESCHEDULING

- Installation also covers up to 2 hours of Software/Media player equipment setup time.

Delays caused by faulty cables, equipment, network issues or caused by issues/conditions outside of LSI's control could result in additional hourly charges of \$150/hr or return trip charges of \$350 plus additional hourly charges of \$150/hr. Out-of-scope installation conditions may result in additional charges of \$150/hr.

“Out-of-Scope” examples include, but are not limited to:

- Faulty / improper electrical service to point of installation
- Improperly installed anchor bolts
- Data cables improperly terminated (or not terminated) Missing / damaged equipment
- Site not ready for LSI technicians at time of arrival
- POS/Network/Firewall issues resulting in delayed/extended provisioning
- Return trips caused by issues/conditions outside of LSI's control will be billed at \$350 Return Trip Charge plus \$150/hr onsite.
- Installation rescheduling within 24 hours prior to the scheduled installation will result in a charge of 75% the installation price.
- Onsite installation cancellation defined as situations when a tech arrives on site and is not able to install due to issues with the customer site readiness will result in a charge of 100% the installation price.

Pricing valid as of Oct 15, 2021

Popeyes Digital Drive Thru Order Form - v200403



FRANCHISE CHECKLIST - OUTDOOR SITE PREPARATION



ELECTRICAL



Power



Electrician

NETWORK

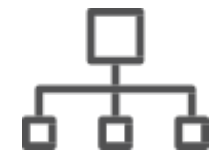

Network Configuration



Network Viability



POS



Confirm Connectivity

FOUNDATION



Footer



Anchor Bolt Pattern



Conduit



Circuit

DATA / ELECTRICAL



PreSell

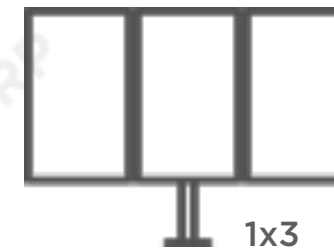

1x3



120V/20A
120V/15A



SAMSUNG



SAMSUNG



QTY-2
SHIELDED
CAT6A



SAMSUNG



120V/20A
120V/15A



SAMSUNG



SAMSUNG



QTY-4
SHIELDED
CAT6A



SAMSUNG

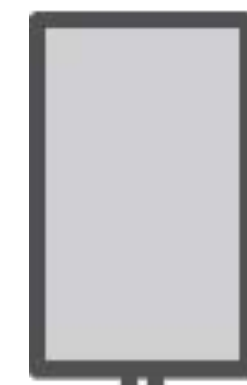

120V/20A SAMSUNG

120V/15A SAMSUNG

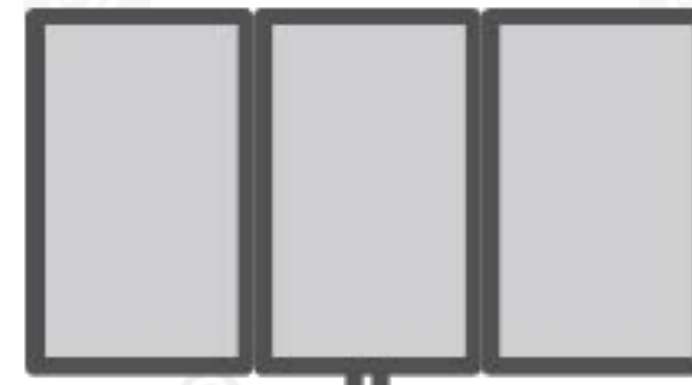

120V/20A SAMSUNG

120V/15A SAMSUNG



3" Conduit Recommended

3/4" Conduit Recommended



FRANCHISE CHECKLIST - INDOOR SITE PREPARATION



ELECTRICAL



Power



Electrician

NETWORK

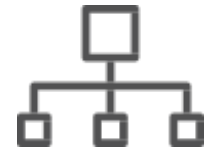

Network Configuration



Network Viability



POS



Confirm Connectivity

DATA / ELECTRICAL



QTY - 4
120V/15A

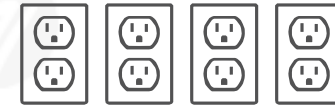

QTY-4
CAT6

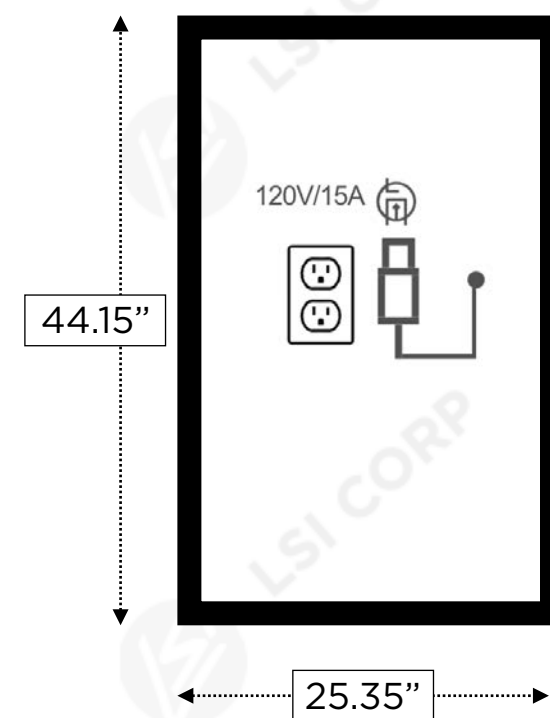

25.35"

Minimum Space Requirements for IDMB Displays

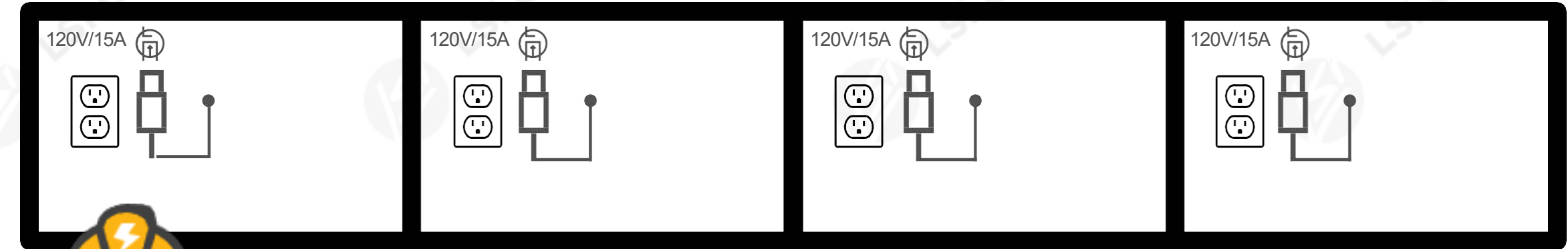
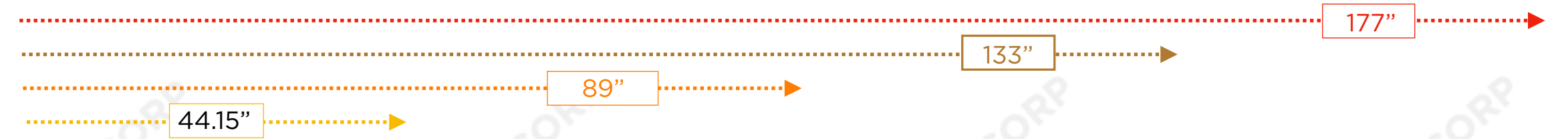

25.35"

44.15"

25.35"



GAN CHEV.ca



**GANANOQUE MOTORS LTD – 439 KING STREET E, GANANOQUE
ON K7G 1G9 613-382-2168**

www.ganchev.ca

March 10, 2023

To Whom It May Concern:

We have received the site plan for the proposed Popeyes Gananoque at 399 King St E,

We feel this restaurant would be a great addition to the main street of Gananoque, and would employ 30 plus people.

As owners of most of the adjacent properties, we fully support this project.

Regards,

Jamie Hall and Dewey Hall

GAN CHEV.ca



2022
PRESIDENT'S CLUB
CANADA

CSN GANANOQUE